

DISCHARGE MEASUREMENTS IN IRRIGATION CANALS USING MULTI-FREQUENCY ACOUSTICS

Mike Cook (PhD), John Sloat, Chris Ward, Mark Tepper

**SonTek/YSI
9940 Summers Ridge Road
San Diego, CA 92121-3091
USA**

Telephone: +1-858-546-8327

FAX: +1-858-546-8150

www.sontek.com

ABSTRACT

Water resource managers are under increased pressure to know flow values in the field. This trend is driven by increased demand for water as well as new models for water pricing. These drivers have created a demand for increased precision and accuracy for water users particularly in the irrigation industry. Accurate flow measurements are the starting point for all resource water management - without accurate flow measurements reliable rating curves and velocity indices, the principle tools used to manage irrigation water, are not valid. SonTek's RiverSurveyor products, the S5 and M9, present end users with a new discharge measurement instrument that is easy to use and highly accurate. Discharge measurements with the S5 or M9 have a high resolution velocity profile, as well as an extended bottom tracking range and an integrated GPS; all of which are required accurate discharge measurements which is crucial for water resource management. Traditional discharge measurements only measure a small fraction of the discharge area thus not providing accurate discharge measurements in complex flow conditions. The application of multi-frequency acoustics allow users to measure discharge from shallow to deep conditions with the same instrument. The echo-sounder measures directly below the instrument to measure cross-sectional area while an integrated GPS allow users to determine discharge in challenging moving bed situations. Thus the combination of multi-frequency acoustics, echo-sounder and integrated GPS allows users to determine discharge quickly and extremely accurately – both of which are important for water resource managers. The RiverSurveyor has been used in irrigation districts and streams throughout the world. Case studies will be presented analyzing a wide range of gauging scenarios in an irrigation setting, while highlighting the benefits of the technological advancement to water resource managers.

INTRODUCTION AND BACKGROUND

The use of hydroacoustic instruments to directly measure discharge in medium to shallow rivers and canals has been around for more than two decades. In the past, this technology

was developed from instrumentation originally designed for oceanographic applications. Specialized software and floating platforms have extended the usability of these instruments in open channels; however, there were limitations caused by instruments operating at a single frequency that reduced the dynamic measurement range of the instrument. A recent advance in commercial microelectronics has greatly increased the capability of these devices intended for discharge measurements, including the ability to operate at multiple frequencies.

Taking into account the increasing demand for water resources and the continuing concerns of the long term impact of global climate change has presented many end users the need for better accounting of water uses. Currently, in Australia there is a 10 year – hundreds of millions of dollars initiative for metering non-urban flow. Closer to home, the State of California has passed a number of Propositions, Proposition 50 for example, that would allocate tens of millions of dollars for the water resource monitoring and water use efficiency. In every case, these initiatives were developed with the idea to move from the old mechanical technologies to the newer highly accurate and precise technologies.

The importance of a good measurement is fundamental to resource management and development of data; without good data the user can make poor and uninformed decisions. A good measurement is driven by site selection, the user's knowledge of "how to" make a proper measurement and measurement instrument capabilities. Typically a good site is easily accessible and has a well defined cross-section or transect. Velocity profiles should be well distributed and flowing perpendicular to the cross-section to be measured. The user "know how" is a key factor for making a discharge measurement and more often than not the user's knowledge of the instrument and the characteristics of the surrounding area guide the user to making an accurate measurement. Instrument capabilities are an important factor in accurately describing flow velocities which is translated into a discharge measurement by multiplying by discharge area. Describing all instrument characteristics is beyond the scope of this paper; however this paper will describe the latest developments in hydro acoustics and presents 5 case studies applying the RiverSurveyor.

Multi – frequency ADP

There are several key developments for the RiverSurveyor that will provide discharge measurement end users with increased accuracy and precision as well as ease of use. The application of multi-frequencies to the acoustic Doppler profiler (ADP) gives the user increased accuracy and precision on shallow to deep measurements without changing modes or configurations. Figure 1 and Figure 2 display schematics for the 5-beam S5 and the 9-beam M9, respectively.

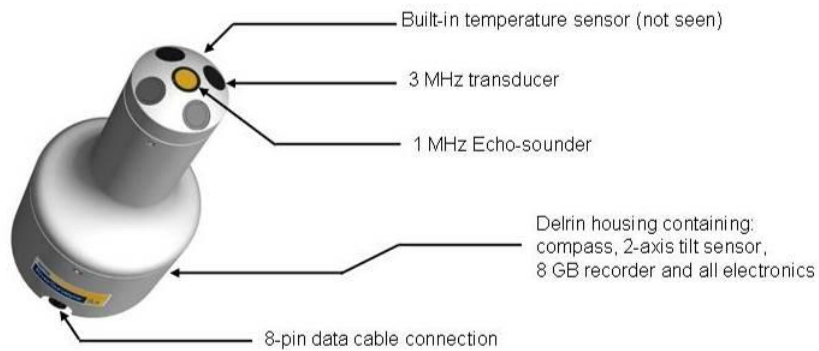

Figure 1. S5 RiverSurveyor ADP

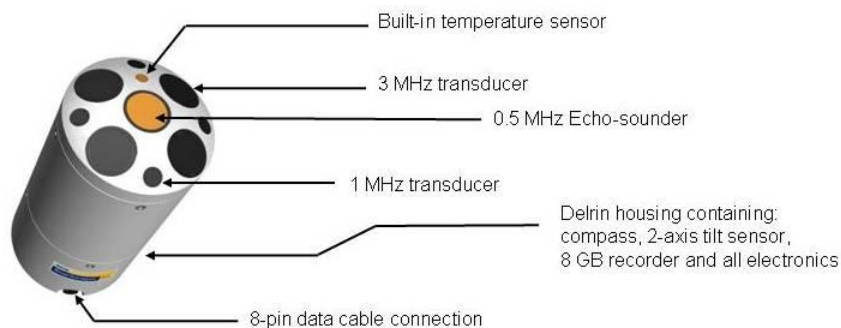

Figure 2. M9 RiverSurveyor ADP

The S5 uses a 1 MHz echo sounder for depth measurement with 4 – 3.0 MHz transducers for bottoming tracking and velocity profiling. The M9 utilizes a 0.5 MHz vertical beam with 4 – 3.0 MHz and 4 – 1.0 MHz transducers for bottom tracking and velocity profiling. In all cases the velocity profiling transducers are configured using a Janus 25° slant angle. The new multi frequency design compounded with increased profiling and depth measurements present the users significant improvements for discharge measurements. Table 1 displays depth and velocity profiling ranges

Table 1. Summary of transducer frequencies and profiling ranges for the S5 and M9

ADP Type	Velocity Profiling Frequencies (MHz)	Vertical Beam Frequency (MHz)	Velocity Profiling Range (m)	Depth Measurement Range (m)
S5	3.0	1.0	0.06 – 5	0.2 – 15
M9	3.0/1.0	0.5	0.06 - 40	0.20 – 80

Power and Communications

The RiverSurveyor Power and Communications Module (PCM) provides integrated solutions for power, communications and navigational information. Each system is supplied with 2 rechargeable battery packs. Each battery pack provides the system power for 6+ hours. In addition, the unit has the capability for short or long range

communications as well as GPS solutions. Figure 3 displays a drawing of the PCM and Figure 4 displays the SonTek Hydroboard which provides quick mounts for the ADP and PCM and is light weight enough for one man operation.

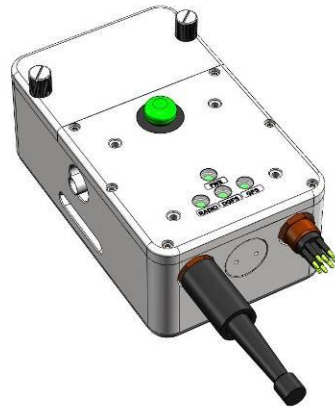

Figure 3. RiverSurveyor PCM



Figure 4. SonTek RiverSurveyor assembled on SonTek Hydroboard

The PCM uses Bluetooth technology for short-range communications while a 900 MHz spread spectrum radio is used for the long range communications. Short range communications utilizes a laptop which has a range up to 200m or a mobile phone platform that has a range up to 60m. The spread spectrum radio has a range to approximately 1,600m.

Table 2 presents a summary of communications options and corresponding range.

Table 2. Summary of communications options and corresponding ranges

Communications Type	Range
Bluetooth	Mobile 200 ft, Laptop PC 200m
900 MHz Spread Spectrum	1,600m

Additional Differential GPS (DGPS) with sub meter accuracy and Real-time Kinematic (RTK) GPS with 3 cm accuracy solutions are integrated into the PCM to provide highly accurate navigation data. These options provide end users a wide range of options for telemetry and present useful and accurate solutions for navigation that are ideal for moving bed situations. Table 3 presents a summary of GPS type and accuracy.

Table 3. Summary of GPS options and corresponding accuracy

Integrated GPS Option	Accuracy (m)
Differential GPS (DGPS)	< 1
Real-time kinematic GPS (RTK)	≤ 0.06

Ease of Use

The Next Generation RiverSurveyor was developed with the user in mind; after a brief set-up there are only five steps to complete a discharge measurement. Figure 5 presents the steps involved in the discharge measurement process. The software design allows the user to measure discharge from shallow to deep water without changing modes or cell sizes, settings automatically change by recognizing water depth and optimal resolution for the discharge measurement. In addition, the data are stored in the ADP making the measurement process stable and flexible. This is an important improvement as it allows the user to connect and disconnect from the ADP and still collect data. Previously all data were stored on the laptop with communications drops due range would require a complete re-start for data collection. Additionally, all Bottom Tracking, GPS and depth data are collected. This allows the user multiple options for discharge calculation during post processing.



Figure 5. Five steps in completing a discharge measurement

Note: Figure above is from the Mobile Platform; while the presentation on the laptop PC is slightly different the steps in the process are exactly the same.

CASE STUDIES

This section will provide a series of case studies explaining the use of the RiverSurveyor in a wide variety of conditions. The case studies include five canals near Yuma, Arizona area that were either a USGS or Imperial Irrigation District (IID) gauged/rated sites. All measurements applied USGS protocols and were conducted on January 15 and 16. Figure 6 presents gauging sites used in this paper.



Figure 6. Locations of gauging sites for case studies

Figure 7 presents a graphical summary of the M9 data collected on the All American Canal –Station 60. The graph in the top portion of the figure compares Bottom Track (BT) and Vertical Beam (VB) data. The Depth Reference data shows good agreement; however the VB better represents the trapezoidal canal, while BT has the tendency to round off corners due to depth determination being the average of the 4 beams in a 25° Janus configuration. The middle graph presents Track Reference data which also provides good agreement. The bottom graph presents velocity profile information across the measured transaction; note the cell velocities go from blue (slow) to red (fast). Overall performance of this site was optimal. It is important to observe that the RiverSurveyor measurement for the site was 3.5% less the gauged value. Observations made at the site indicate that instruments used in development of the rating curve had a much higher standard deviation (on the order of 10-fold or more) than the RiverSurveyor measurements conducted at the site.

Table 4 presents a summary of the data collected in the field. The table provides details for Track and Depth References used for the measurements. It can be observed from the data that overall system performance was excellent with covariance measurements ranging between 0.004 - 0.044 (or 0.4 - 4.4%) while the difference from gauged values ranged from -3.5 - +0.4%. It is important to consider that rating curves for the site were developed using different instruments.

Figure 7 presents a graphical summary of the M9 data collected on the All American Canal –Station 60. The graph in the top portion of the figure compares Bottom Track (BT) and Vertical Beam (VB) data. The Depth Reference data shows good agreement; however the VB better represents the trapezoidal canal, while BT has the tendency to round off corners due to depth determination being the average of the 4 beams in a 25° Janus configuration. The middle graph presents Track Reference data which also provides good agreement. The bottom graph presents velocity profile information across the measured transaction; note the cell velocities go from blue (slow) to red (fast). Overall performance of this site was optimal. It is important to observe that the RiverSurveyor measurement for the site was 3.5% less the gauged value. Observations made at the site indicate that instruments used in development of the rating curve had a much higher standard deviation (on the order of 10-fold or more) than the RiverSurveyor measurements conducted at the site.

Table 4. Summary of data collected in the Lower Colorado River Basin

Station	Q_{RS} (m³/s)	Track/Depth	STD DEV	COV	Q_{Gauge} (m³/s)	% Dif
All American Station 60	129.5	RTK [*] /VB ⁺	0.534	0.004	134.22	-3.5
Gila Gravity Main	24.26	Bottom Track/Beam	0.366	0.015	24.18	+0.4
Reservation Main	2.78	VTG [#] /VB ⁺	0.121	0.044	2.83	-2.0
Welton Mohawk Main	13.28	RTK [*] /VB ⁺	0.172	0.013	13.30	---
Welton Mohawk Drain	5.32	RTK[*]/VB⁺	0.089	0.017	5.30	---

^{*}RTK refers to Real Time Kinematic GPS

⁺VB refers to Vertical Beam

[#]VTG refers to the VTG GPS string using a differential GPS correction

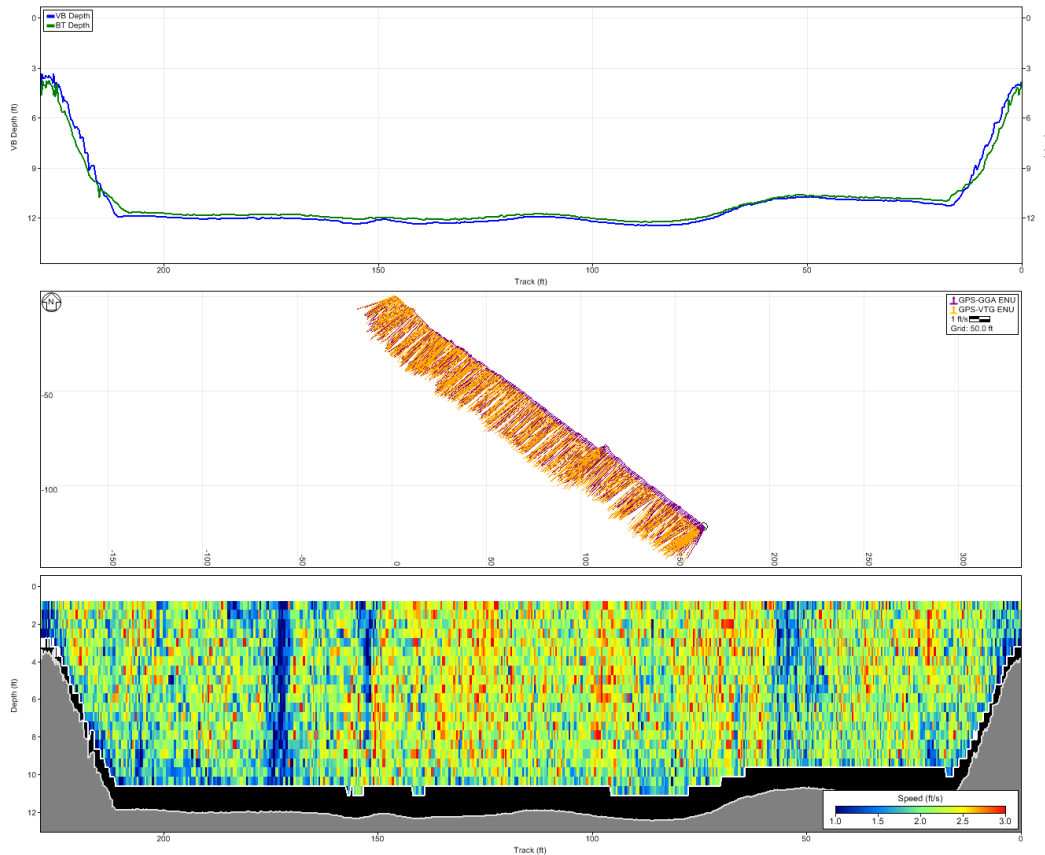

Figure 7. Data View - All American Canal Station 60

Figure 8 displays M9 data collected Gila Gravity Main Canal. The Gila Gravity Main Canal is a considerably smaller trapezoidal concrete channel than the All American Canal Station 60, however performance was similar recording a covariance of 0.015 (precision) for the four transects with a 0.4% difference from gauge rating. Depth Reference data was good with only slight variations observed in BT and VB data, while the same conclusions can be applied to Track Reference information. The bottom graph in Figure 8 displays velocity profile data (cell velocity data). It can be observed in this data that cell sizes on the left and right margins are larger than the cells in the middle of the transect. This can be explained by the M9 shifting from the 3 MHz transducers to the 1 MHz transducers, cell size and frequency hopping are done automatically based on depth.

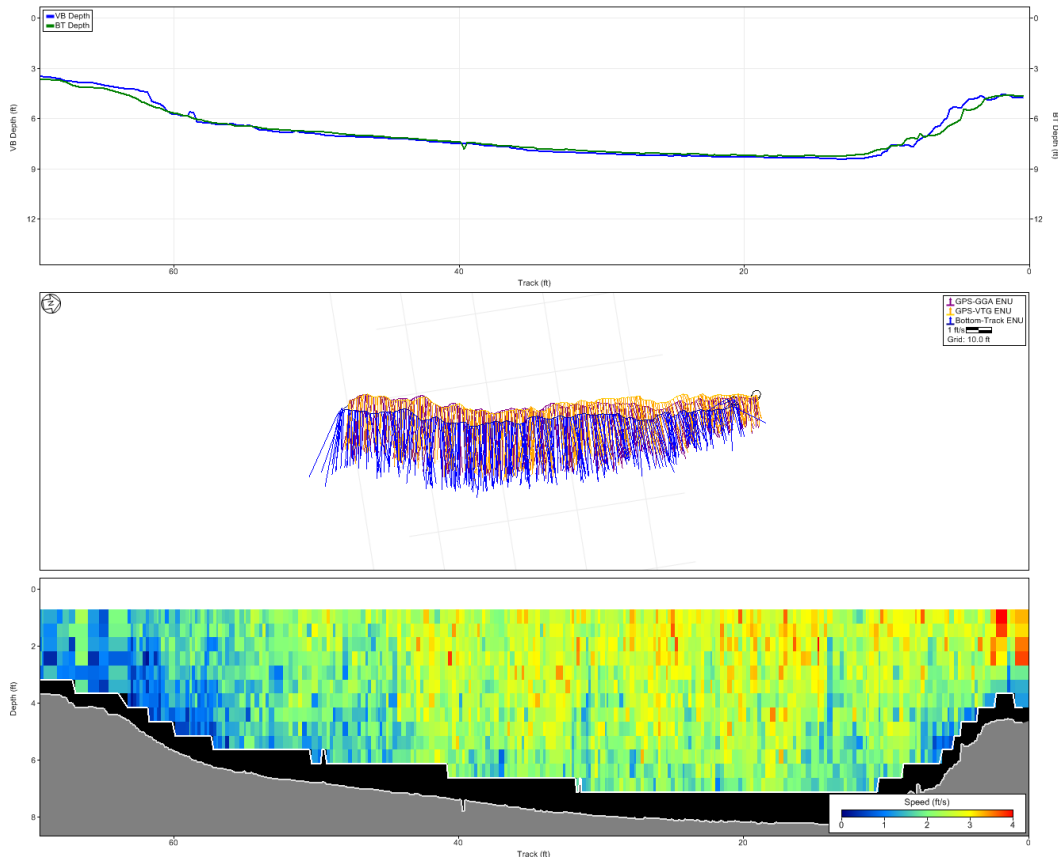

Figure 8. Data View – Gila Gravity Canal

Figure 9 highlights the S5 data from the Reservation Main Canal (USGS Station 09522500). The S5 collected almost equivalent data for Depth and Track Reference data for the earthen channel. BT data was not used in this case as the Reservation Main Canal is an earthen canal with deposits fine sediments on the bottom of the canal which proposes a potential problem for a moving bed. RTK GPS was not utilized for this paper in an effort to evaluate the performance of the VTG Track data in small to medium sized canals. Overall performance was good with a 0.044 value for Covariance and a -2.0% difference with the rated value. Observations can be made from the bottom graph as velocity profiling cell sizes changed automatically from smaller sizes (5 cm) on the edges to larger cell sizes (15 cm) in the middle of the transect as depth of the canal increased.

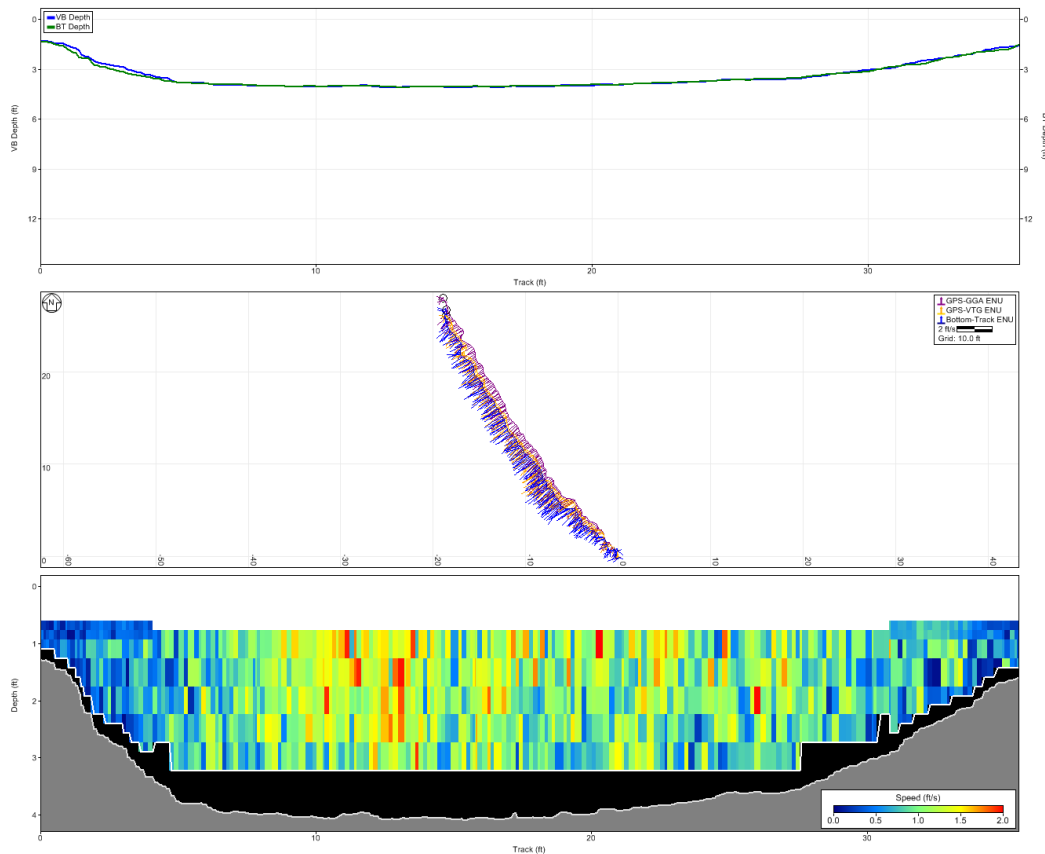

Figure 9. Data View – Reservation Main

Figure 10 presents the data collected at the Welton Mohawk Main Canal using RTK GPS for Track Reference and the VB for Depth Reference. Results of gaugings for the trapezoidal concrete canal were identical to the rated value (13.30 cms) with a standard deviation of 0.172 cms and a covariance of 0.013. Observations of the data indicate that the left edge has a significant build-up of sediments, approximately 0.92m with the highest velocities measured on the right edge of the canal. The Depth Reference data had slight discrepancies and this can be attributed to the steep walled trapezoidal canal and the depth calculation of the beam data and corresponding calculation. All Track Reference data were consistent with each other indicating that all data were valid for this gauging. It can be observed from the bottom graph that at approximately 2.44 of depth, the S5 automatically shifted from 5 cm cell size to a 15 cm cell size.

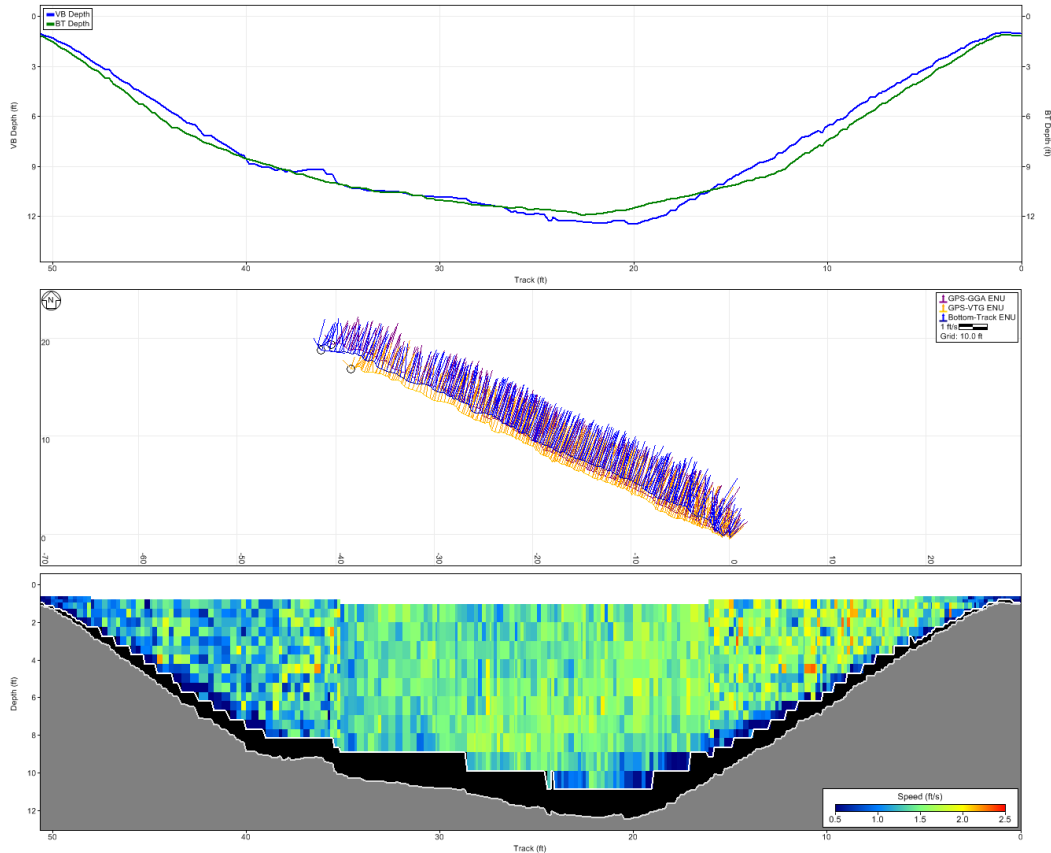

Figure 10. Data View - Welton Mohawk Main

Figure 11 presents data collected at the Welton Mohawk Drain. Depth Reference data was good with only slight differences observed in the BT and VB data. However Track Reference data shows a major discrepancy between the GPS data and the BT data. The BT data indicates the track moving upstream while the GPS data presents a fairly straight line closing the transect. BT data indicates the presence of a moving bed therefore this data is not valid for the discharge measurement. Using the RTK GPS track information and VB data for Depth Reference the S5 data matched the rated values, with the S5 data presenting a standard deviation of 0.0889 cms (covariance of 0.017). Observations at the site indicated the presence of thick algae attached the bottom of the concrete lined channel. These algae would bias the Track data, making it appear that the rover is moving upstream; this also would bias the velocity data by decreasing the water velocity measurements and therefore decreasing the overall measured discharge.

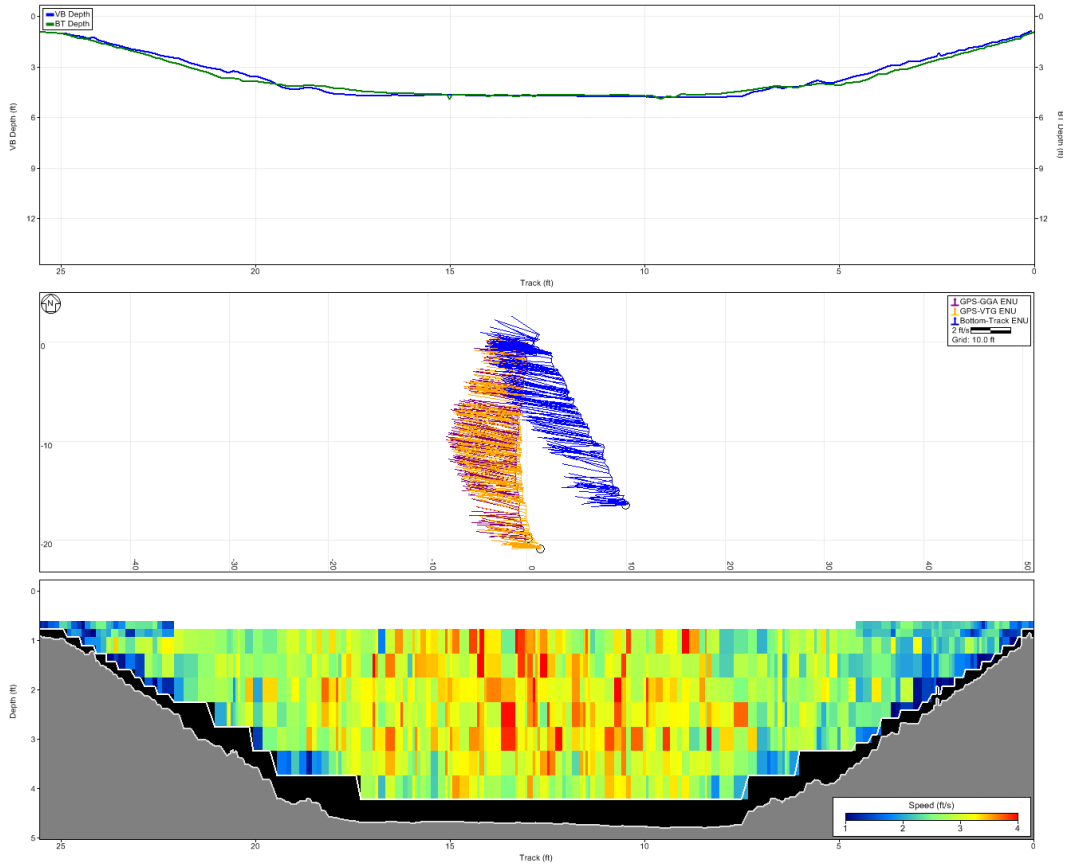

Figure 11. Data View – Welton Mohawk Drain

CONCLUSIONS

The case studies presented above indicate the RiverSurveyor is highly accurate when comparing discharge measurements to rated values of the USGS and IID, overall percent differences range from -3.5 to +0.4 % . In addition, that data presented demonstrates a high level of precision of the measurements with covariance ranging from 0.004 to 0.044. The multiple Track and Depth data provide valuable information about the measured sites, such as sediment build up, velocity profile data and detection of moving beds.

The system provides a high degree of flexibility, collecting multiple Track and Depth data references which allow the user many options in post processing and discharge measurement calculations. The examples above described combining the vertical beam data with RTK GPS data, Beam and VTG GPS data to determine discharge. Best case scenario would be to always have RTK GPS information available in order to make viable measurements in the case of moving bed sites which are typical of flooding events, plant growth and other potential complications. The system is easy to use with site set-up and preparation taking less than 10 minutes, which includes obtaining an RTK lock. Data collection follows the 5 steps described above while the RiverSurveyor applies automatic cell size adjustments based on water depth, this allows users to focus on the process of data collection and not instrument configuration.

Lastly and most importantly, the precision and accuracy of the data collected in the field allow end users and water resource managers to know the field conditions and thus make informed decisions. Typically real time flow monitoring is done with water level measurements or velocity measurements correlated to a wide range of discharge measurements – thus the accuracy of discharge measurements is critical for making informed decisions.